

LEITUNGEN

1.2 Leitungskenngrössen

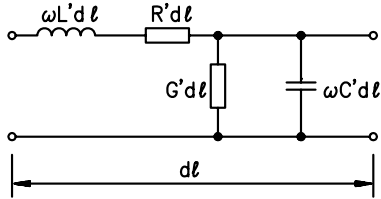

Induktionsbelag L' (H/m)

$$L' = \frac{Z_o \sqrt{\epsilon_r}}{c_o} \quad \text{L1.3}$$

$$c_o = 3 \cdot 10^8 \text{ m/s}$$

Kapazitätsbelag C' (F/m)

$$C' = \frac{\sqrt{\epsilon_r}}{c_o Z_o} \quad \text{L1.4}$$

Übertragungsbelag

$$\gamma = \alpha + j\beta = \sqrt{(R' + j\omega L')(G' + j\omega C')} = \sqrt{Z' Y'} \quad \text{L1.8}$$

Dämpfungsbelag α (Np/m)

$$\alpha = \frac{R'}{2Z_o} + \frac{G' Z_o}{2} \quad \text{L1.9}$$

$$1 \text{ Np} = 8.686 \text{ dB}$$

Phasenbelag β (Rad/Längeneinheit)

$$\beta = \omega \sqrt{L' C'} = \frac{2\pi}{\lambda} = \frac{\omega}{v} \quad \text{L1.10}$$

Wellenwiderstand Z_o (Ω)

$$Z_o = \sqrt{\frac{R' + j\omega L'}{G' + j\omega C'}} = R_L + jX_L = \sqrt{\frac{Z'}{Y'}} \quad \text{L1.12}$$

$$Z_o = \frac{U_h}{I_h} = -\frac{U_r}{I_r} \quad \text{L1.13}$$

1.3 Frequenzabhängigkeit der Leitungsbeläge

$$Z_o = \sqrt{\frac{R' + j\omega L'}{G' + j\omega C'}} = \sqrt{\frac{L'}{C'}} \sqrt{\frac{1 - j \frac{R'}{\omega L'}}{1 - j \frac{G'}{\omega C'}}} \quad \text{L1.15}$$

$$f > 10 \text{ kHz} \quad Z_o \approx \sqrt{\frac{L'}{C'}} \quad \text{L1.18}$$

2. Dimensionierung von Leitungen**2.1 Feldwellenwiderstand**

$$Z_F = \frac{E}{H} \quad \text{L2.1}$$

$$Z_F = \frac{E_h}{H_h} = -\frac{E_r}{H_r} \quad \text{L2.2}$$

$$\frac{E_h}{H_h} = Z_F = \sqrt{\frac{\mu_0 \mu_r}{\epsilon_0 \epsilon_r}} = Z_{F0} \sqrt{\frac{\mu_r}{\epsilon_r}} \quad \text{L2.3}$$

$$Z_{F0} = \sqrt{\frac{\mu_0}{\epsilon_0}} = 120\pi \, \Omega = 377\Omega \quad \text{L2.4}$$

$$Z_F = \frac{Z_{F0}}{\sqrt{\epsilon_r}} < 377\Omega$$

2.2.1 aus Kapazitätsbelag

$$v = \frac{1}{\sqrt{L' C'}} \quad \text{und} \quad Z_0 = \sqrt{\frac{L'}{C'}} \quad v = \frac{\omega}{\beta} = \frac{c}{\sqrt{\epsilon_r}}$$

$$c = \frac{1}{\sqrt{\mu_0 \epsilon_0}} \approx 3 \cdot 10^{10} \frac{\text{cm}}{\text{s}}$$

$$Z_0 \cdot v = \sqrt{\frac{L'}{C'}} \cdot \frac{1}{\sqrt{L' C'}} = \frac{1}{C'} \quad \text{L2.5}$$

$$Z_0 = \frac{\sqrt{\epsilon_r}}{C'} \frac{1}{c} \quad \text{L2.6}$$

$$Z_0 = \frac{\sqrt{\epsilon_r}}{C'} \cdot \frac{1}{3 \cdot 10^{10}} \cdot \frac{\text{s}}{\text{cm}}$$

$$Z_0 = 33.3\Omega \sqrt{\epsilon_r} \frac{1}{C'} \cdot \frac{\text{pF}}{\text{cm}} \quad \text{L2.7}$$

2.2.2 aus Induktivitätsbelag

$$Z_0 = \sqrt{\frac{L'}{C'}} \quad v = \frac{1}{\sqrt{L' C'}} \quad v = \frac{c}{\sqrt{\epsilon_r}}$$

$$L' = \frac{Z_0}{v} \quad \text{L2.8}$$

$$Z_0 = \frac{L'}{\sqrt{\epsilon_r}} \cdot 3 \cdot 10^{10} \frac{\text{cm}}{\Omega\text{s}} = \frac{30 L' \text{ cm}}{\sqrt{\epsilon_r} \text{ nH}} \quad \text{L2.9}$$

2.2.3 mit Feldtheorie

$$Z_0 = \frac{U}{I} = \frac{\int E \, da}{\int H \, db} = \frac{\Delta U \cdot n_E}{\Delta l \cdot n_H} = \frac{E \cdot \Delta a}{H \cdot \Delta b} \cdot \frac{n_E}{n_H} = Z_F \frac{\Delta a \cdot n_E}{\Delta b \cdot n_H} = \frac{Z_{F0}}{\sqrt{\epsilon_r}} \cdot \frac{\Delta a \cdot n_E}{\Delta b \cdot n_H} = \frac{377 \Omega}{\sqrt{\epsilon_r}} \cdot \frac{\Delta a \cdot n_E}{\Delta b \cdot n_H}$$

2.3 Spannungsbeanspruchung, Leitungsdämpfung, Wärmebegrenzung

$$E_{\max} = \frac{C'U}{\pi \epsilon_0 \epsilon_r} \cdot \frac{1}{d} = \frac{2U}{d \ln \frac{D}{d}} \quad \text{L2.13}$$

$$p_v = -\frac{dP(z)}{dz} = 2\alpha P_0 e^{-2\alpha z} = 2\alpha P \quad \text{L2.16}$$

$$\alpha \approx \frac{1}{2} \cdot \frac{R'}{Z_0} + \frac{1}{2} \cdot G' Z_0 = \alpha_R + \alpha_G \quad \alpha_R = \frac{1}{2} \cdot \frac{R'}{Z_0} \quad \alpha_G = \frac{1}{2} \cdot G' Z_0$$

$$\alpha_G = \pi f \frac{\sqrt{\epsilon_r}}{c} \tan \delta_G \quad \text{L2.18}$$

$$\alpha_G = 1.05 \cdot f \sqrt{\epsilon_r} \tan \delta_G \frac{10^{-2}}{\text{m} \cdot \text{MHz}} \quad \text{L2.19}$$

$$\alpha_R = \frac{1}{2\pi Z_0} \left(\frac{1}{d} + \frac{1}{D} \right) \sqrt{\pi \rho \mu f} \quad \text{L2.22}$$

$$\alpha_G \sim f \quad \text{L2.23}$$

$$\alpha_R \sim \sqrt{f} \quad \text{L2.24}$$

$$p_v \approx 2\alpha_R P \sim \sqrt{f} \cdot P \quad \text{L2.25}$$

Soll p_v einen bestimmten höchstzulässigen Wert nicht überschreiten, so muss das Produkt $P\sqrt{f}$ konstant gehalten werden. Die übertragbare Leistung fällt also mit der Wurzel aus der Frequenz.

2.4 Optimale Koaxkabel

$$Z_0 = \frac{120\pi \Omega \ln \frac{D}{d}}{2\pi \sqrt{\epsilon_r}} = \frac{60\Omega}{\sqrt{\epsilon_r}} \ln \frac{D}{d} \quad \text{L2.29}$$

2.4.2 Kabel minimaler Dämpfung

$$F_{\alpha} \equiv \alpha_R \frac{Z_{F0} D}{R_F \sqrt{\epsilon_r}} = \frac{1 + \frac{D}{d}}{\ln \frac{D}{d}} \quad x = \frac{D}{d} = 3.6$$

$$Z_{o\alpha} = \frac{77\Omega}{\sqrt{\epsilon_r}} \quad \text{L2.31}$$

2.4.3 Kabel grösster Spannungsfestigkeit

$$F_E \equiv \frac{E_{\max} D}{2U} = \frac{\frac{D}{d}}{\ln \frac{D}{d}} \quad \frac{D}{d} = 2.718$$

$$Z_{oE} = \frac{60\Omega}{\sqrt{\epsilon_r}} \quad \text{L2.33}$$

2.4.4 Kabel bester Leistungsübertragung

$$F_P \equiv 100P \frac{240\Omega}{(DE_{\max})^2 \sqrt{\epsilon_r}} = 100 \frac{\ln \frac{D}{d}}{2 \left(\frac{D}{d}\right)^2} \quad \frac{D}{d} = \sqrt{e} = 1.65$$

$$Z_{oP} = \frac{30\Omega}{\sqrt{\epsilon_r}} \quad \text{L2.37}$$

2.4.5 Zusammenfassung**Dämpfungsoptimiertes Kabel:**

$$Z_{o\alpha} \sqrt{\epsilon_r} = 77\Omega \quad \text{L2.38}$$

Spannungsoptimiertes Kabel:

$$Z_{oE} \sqrt{\epsilon_r} = 60\Omega \quad \text{L2.39}$$

Leistungsoptimiertes Kabel:

$$Z_{oP} \sqrt{\epsilon_r} = 30\Omega \quad \text{L2.40}$$

Isoliermaterial	ϵ_r	50Ω-Kabel $Z_o\sqrt{\epsilon_r}$	75Ω-Kabel $Z_o\sqrt{\epsilon_r}$
Voll-PE	2.28	75.5 Ω	113 Ω
PTFE/FEP	2.1	72.5 Ω	108 Ω
Schaum-PE	1.5	61.2 Ω	92 Ω
Luft/Vakuum	1.0	50.0 Ω	75 Ω

2.5 Verschieden HF-Leitungen

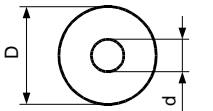
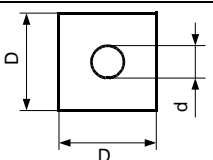
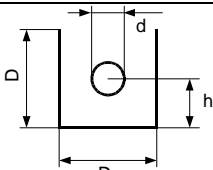
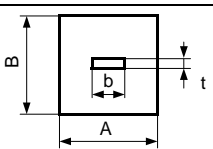
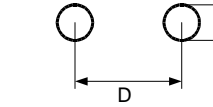
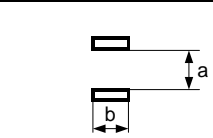
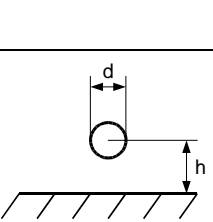
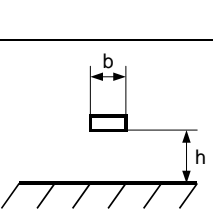
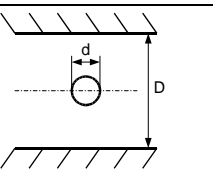
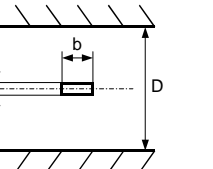
	$Z_0 = \frac{60 \Omega}{\sqrt{\epsilon_r}} \ln \frac{D}{d}$
	$Z_0 = \frac{60 \Omega}{\sqrt{\epsilon_r}} \ln \left(1.078 \frac{D}{d} \right) \quad d/D < 0.8$
	$Z_0 = \frac{60 \Omega}{\sqrt{\epsilon_r}} \ln \left(\frac{4d \cdot \tanh \left(\frac{\pi h}{D} \right)}{\pi d} \right) \quad d \ll h \quad d \ll D$
	$Z_0 = \frac{60 \Omega}{\sqrt{\epsilon_r}} \ln \frac{A+B}{b+t}$
	$Z_0 = \frac{120 \Omega}{\sqrt{\epsilon_r}} \ln \left(\frac{D}{d} + \sqrt{\left(\frac{D}{d} \right)^2 - 1} \right)$
	$Z_0 = \frac{377 \Omega}{\sqrt{\epsilon_r}} \frac{a}{b} \quad a < b$ $Z_0 = \frac{120 \Omega}{\sqrt{\epsilon_r}} \ln \frac{4a}{b} \quad a > b$
	$Z_0 = \frac{60 \Omega}{\sqrt{\epsilon_r}} \ln \left(\frac{2h}{d} + \sqrt{\left(\frac{2h}{d} \right)^2 - 1} \right)$ $Z_0 = \frac{60 \Omega}{\sqrt{\epsilon_r}} \ln \frac{4h}{d} \quad d \ll h$
	$Z_0 = \frac{377 \Omega}{\sqrt{\epsilon_r}} \frac{h}{b} \quad h < b$ $Z_0 = \frac{60 \Omega}{\sqrt{\epsilon_r}} \ln \frac{8h}{b} \quad h > b$
	$Z_0 = \frac{60 \Omega}{\sqrt{\epsilon_r}} \ln \frac{4D}{\pi d} \quad d/D < 0.75$
	$Z_0 = \frac{60 \Omega}{\sqrt{\epsilon_r}} \ln \left(\frac{\frac{8}{\pi}}{\frac{b}{D} + 1.4 \frac{t}{D}} \right) \quad t \leq 0.25D \quad b \leq 0.35(D-t)$

3. Spannungs- und Stromverteilung auf der Leitung

$$U_1 = U_2 \cosh \gamma \ell + I_2 Z_0 \sinh \gamma \ell \quad \text{L3.9}$$

$$I_1 = I_2 \cosh \gamma \ell + \frac{U_2}{Z_0} \sinh \gamma \ell \quad \text{L3.10}$$

$$U_1 = U_z \cosh \gamma z + I_z Z_0 \sinh \gamma z \quad \text{L3.11}$$

$$I_1 = I_z \cosh \gamma z + \frac{U_z}{Z_0} \sinh \gamma z \quad \text{L3.12}$$

$$\gamma \ell = \alpha \ell + j\beta \ell = \alpha \ell + j \frac{2\pi}{\lambda} \cdot \ell$$

$$U(z) = U_{1h} e^{-\alpha z} e^{-j \frac{2\pi z}{\lambda}} + U_{1r} e^{\alpha z} e^{j \frac{2\pi z}{\lambda}} \quad \text{L3.13}$$

$$I(z) = \frac{U_{1h}}{Z_0} e^{-\alpha z} e^{-j \frac{2\pi z}{\lambda}} - \frac{U_{1r}}{Z_0} e^{\alpha z} e^{j \frac{2\pi z}{\lambda}} \quad \text{L3.14}$$

$$\frac{U_1}{U_2} = \left(1 + \frac{Z_0}{Z_2}\right) \frac{e^{\gamma \ell}}{2} + \left(1 - \frac{Z_0}{Z_2}\right) \frac{e^{-\gamma \ell}}{2} \quad \text{L3.15}$$

$$\frac{I_1}{I_2} = \left(1 + \frac{Z_2}{Z_0}\right) \frac{e^{\gamma \ell}}{2} + \left(1 - \frac{Z_2}{Z_0}\right) \frac{e^{-\gamma \ell}}{2} \quad \text{L3.16}$$

Für $Z_2 = Z_0$ verschwindet die reflektierte Welle (ideale Anpassung).

In diesem Fall bleibt

$$\frac{U_1}{U_2} = e^{\gamma \ell} \quad \frac{I_1}{I_2} = e^{\gamma \ell} \quad \frac{U_1}{I_1} = \frac{U_2}{I_2} = Z_0 \quad \text{L3.17}$$

4. Eingangswiderstand und Reflexionsfaktor

$$Z_2 = \frac{U_2}{I_2} = Z_0 \frac{U_{2h} + U_{2r}}{U_{2h} - U_{2r}} = Z_0 \frac{1 + \frac{U_{2r}}{U_{2h}}}{1 - \frac{U_{2r}}{U_{2h}}} = Z_0 \frac{1 + r_2}{1 - r_2} \quad \text{L 4.2}$$

$$r_2 = \frac{Z_2 - Z_0}{Z_2 + Z_0} \quad \text{L4.3}$$

$$r_1 = |r_2| e^{-2\alpha \ell} e^{-j \frac{4\pi \ell}{\lambda}} e^{j\varphi} = |r_2| e^{-2\alpha \ell} e^{j\left(\varphi - \frac{4\pi \ell}{\lambda}\right)} \quad \text{Winkel in Rad} \quad \text{L4.4}$$

$$r_1 = |r_2| e^{-2\alpha \ell} \angle \varphi - \frac{720^\circ \cdot \ell}{\lambda} \quad \text{Winkel in Grad}$$

$$\alpha = \frac{\text{Np}}{\text{Längeneinheit}} \quad 1 \text{ Np} = 8.686 \text{ dB} \quad 1 \text{ dB} = 0.1151 \text{ Np}$$

$$Z_1 = Z_0 \frac{Z_2 + Z_0 \tanh \gamma l}{Z_0 + Z_2 \tanh \gamma l} \quad \text{L4.5}$$

Zusammenhänge der verschiedenen Reflexionsgrößen

$$r = \frac{U_r}{U_h} = -\frac{I_r}{I_h} = \frac{Z_2 - Z_0}{Z_2 + Z_0} = |r| \angle \varphi \quad |r| = \frac{s-1}{s+1} = \frac{1-m}{1+m} = 10^{\frac{\text{RL}}{20}} = \frac{|Z_2 - Z_0|}{|Z_2 + Z_0|}$$

$$r \text{ [dB]} = -20 \cdot \log \frac{1}{|r|}$$

$$s = \text{VSWR} = \frac{|U_{\max}|}{|U_{\min}|} = \frac{|I_{\max}|}{|I_{\min}|} = \frac{|U_h + U_r|}{|U_h - U_r|} = \frac{1}{m} = \frac{1+|r|}{1-|r|} = \frac{1+10^{\frac{\text{RL}}{20}}}{1-10^{\frac{\text{RL}}{20}}} = \left. \frac{|Z_0|}{|Z_2|} \right|_{Z_2 < Z_0} = \left. \frac{|Z_2|}{|Z_0|} \right|_{Z_2 > Z_0}$$

$$s \text{ [dB]} = 20 \cdot \log s$$

$$m = \frac{|U_{\min}|}{|U_{\max}|} = \frac{|I_{\min}|}{|I_{\max}|} = \frac{|U_h - U_r|}{|U_h + U_r|} = \frac{1}{s}$$

$$\text{RL} = 10 \cdot \log \frac{P_h}{P_r} = -20 \cdot \log |r| = -20 \cdot \log \frac{s-1}{s+1} = -20 \cdot \log \frac{1-m}{1+m} = -20 \cdot \log \frac{|Z_2 - Z_0|}{|Z_2 + Z_0|}$$

RL [dB]	r	VSWR	RL [dB]	r	VSWR
1	0.891	17.39	21	0.089	1.196
2	0.794	8.72	22	0.079	1.173
3	0.708	5.85	23	0.071	1.152
4	0.631	4.42	24	0.063	1.135
5	0.562	3.57	25	0.056	1.119
6	0.501	3.01	26	0.050	1.106
7	0.447	2.61	27	0.045	1.094
8	0.398	2.32	28	0.040	1.083
9	0.355	2.10	29	0.035	1.074
10	0.316	1.92	30	0.032	1.065
11	0.282	1.78	31	0.028	1.058
12	0.251	1.67	32	0.025	1.052
13	0.224	1.58	33	0.022	1.046
14	0.200	1.50	34	0.020	1.041
15	0.178	1.43	35	0.018	1.036
16	0.158	1.38	38	0.013	1.025
17	0.141	1.33	40	0.010	1.020
18	0.126	1.29	46	0.005	1.010
19	0.112	1.25	50	0.003	1.006
20	0.100	1.22			

5. Verlustlose Leitungen

$$U_1 = \frac{U_2 + Z_0 I_2}{2} e^{j\frac{2\pi\ell}{\lambda}} + \frac{U_2 - Z_0 I_2}{2} e^{-j\frac{2\pi\ell}{\lambda}} \quad \text{L5.1}$$

$$I_1 = \frac{U_2 + Z_0 I_2}{2Z_0} e^{j\frac{2\pi\ell}{\lambda}} - \frac{U_2 - Z_0 I_2}{2Z_0} e^{-j\frac{2\pi\ell}{\lambda}} \quad \text{L5.2}$$

$$U_1 = U_2 \cos \frac{2\pi\ell}{\lambda} + jZ_0 I_2 \sin \frac{2\pi\ell}{\lambda} \quad \text{L5.3 L5.4}$$

$$I_1 = I_2 \cos \frac{2\pi\ell}{\lambda} + j \frac{U_2}{Z_0} \sin \frac{2\pi\ell}{\lambda}$$

5.2 Eingangswiderstand und Reflexionsfaktor

$$Z_1 = Z_0 \frac{Z_2 + jZ_0 \tan \frac{2\pi\ell}{\lambda}}{Z_0 + jZ_2 \tan \frac{2\pi\ell}{\lambda}} \quad \text{L5.6}$$

$$Z_2 = 0 \quad (\text{Kurzschluss}) \quad Z_{10} = jZ_0 \tan \frac{2\pi\ell}{\lambda} \quad \text{L5.8}$$

Daraus folgt:

$$Z_1 \quad \text{ist induktiv f\u00fcr } 0 < \ell < \frac{\lambda}{4}$$

$$Z_1 \quad \text{ist } \infty \text{ f\u00fcr } \ell = \frac{\lambda}{4}$$

$$Z_1 \quad \text{ist kapazitiv f\u00fcr } \frac{\lambda}{4} < \ell < \frac{\lambda}{2}$$

$$Z_1 \quad \text{ist } 0 \text{ f\u00fcr } \ell = \frac{\lambda}{2}$$

$$Z_2 = \infty \quad (\text{Leerlauf}) \quad Z_{1\infty} = -jZ_0 \cot \frac{2\pi\ell}{\lambda} \quad \text{L5.9}$$

Daraus folgt:

$$Z_1 \quad \text{ist kapazitiv f\u00fcr } 0 < \ell < \frac{\lambda}{4}$$

$$Z_1 \quad \text{ist } 0 \text{ f\u00fcr } \ell = \frac{\lambda}{4}$$

$$Z_1 \quad \text{ist induktiv f\u00fcr } \frac{\lambda}{4} < \ell < \frac{\lambda}{2}$$

$$Z_1 \quad \text{ist } \infty \text{ f\u00fcr } \ell = \frac{\lambda}{2}$$

Z_{10} = Eingangsimpedanz bei $Z_2 = 0$

$Z_{1\infty}$ = Eingangsimpedanz bei $Z_2 = \infty$

$$Z_{10} = jZ_o \tan \beta l \quad \beta = \frac{2\pi}{\lambda}$$

$$Z_{1\infty} = -jZ_o \cot \beta l$$

$$Z_{10} \cdot Z_{1\infty} = j \cdot (-j) Z_o^2 \tan \beta l \cdot \cot \beta l = Z_o^2$$

$$Z_o = \sqrt{Z_{10} \cdot Z_{1\infty}} \quad \beta l = \tan^{-1} \sqrt{-\frac{Z_{10}}{Z_{1\infty}}} \quad \text{L5.10}$$

$$l = \frac{\lambda}{4} \quad Z_1 = \frac{Z_o^2}{Z_2} \quad \text{L5.11}$$

$$l = \frac{\lambda}{2} \quad Z_1 = Z_2 \quad \text{L5.12}$$

$$\alpha l = 0$$

$$r_1 = r_2 e^{-j\frac{4\pi l}{\lambda}} \quad \text{L5.13}$$

$$r_1 = |r_2| e^{j\varphi} e^{-j\frac{4\pi l}{\lambda}} = |r_2| e^{j\left(\varphi - \frac{4\pi l}{\lambda}\right)} \quad \text{L5.14}$$

$$|r_1| = |r_2| = \frac{1-m}{1+m} = \frac{s-1}{s+1} \quad \text{L5.15}$$

6. Ausbreitungsgeschwindigkeit

$$v_d = \frac{c_o}{\sqrt{\epsilon_r}} \quad \text{L6.2}$$

$$v_r = \frac{1}{\sqrt{\epsilon_r}} \quad \text{L6.3}$$

$$l_{\text{mech}} = \frac{l_{\text{el}}}{\sqrt{\epsilon_r}} = l_{\text{el}} v_r \quad \text{L6.4}$$

7. Leitungen als Schaltungsbauteile

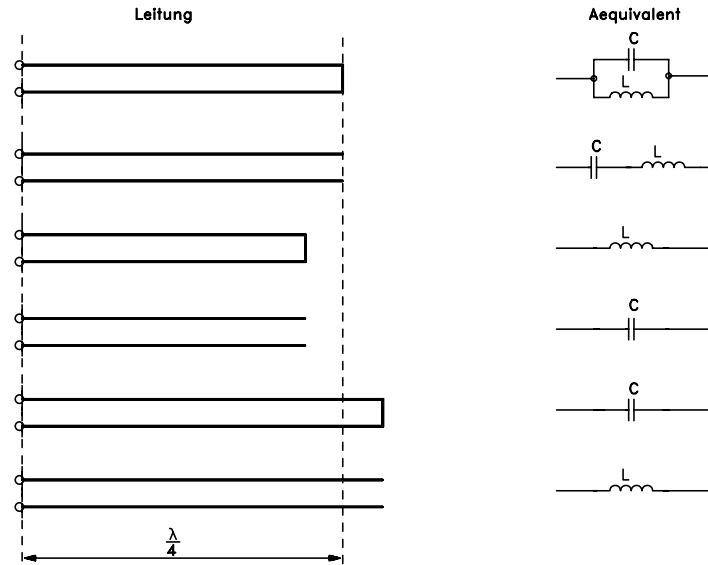

7.1 $\lambda/4$ -Transformator

$$Z_1 = \frac{Z_0^2}{Z_2}$$

7.3 Nonsynchronous-Transformer

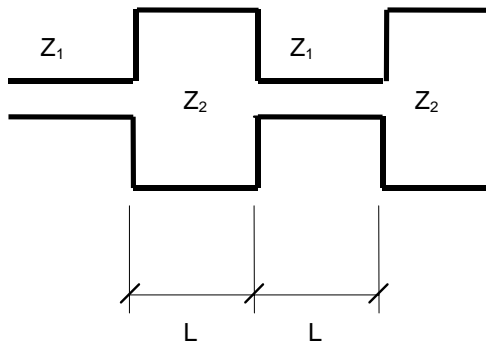

L = Leitungslänge einer Sektion

$$R = Z_1 / Z_2$$

$$L = \frac{\lambda}{2\pi\sqrt{\epsilon_r}} \operatorname{atan} \left(\frac{1}{\sqrt{R + \frac{1}{R} + 1}} \right)$$

8. Smith-Diagramm

Impedanzebene

$$Z = R \pm jX$$

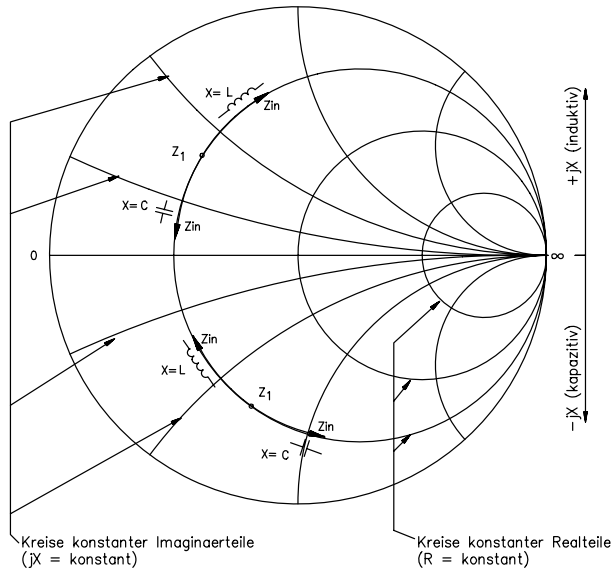

Admittanzebene

$$Y = G \pm jB$$

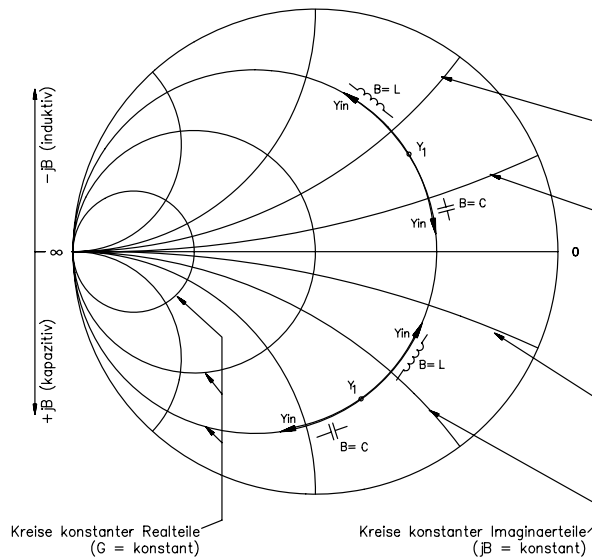

Reflexionsfaktor

$$r = |r| / \varphi$$

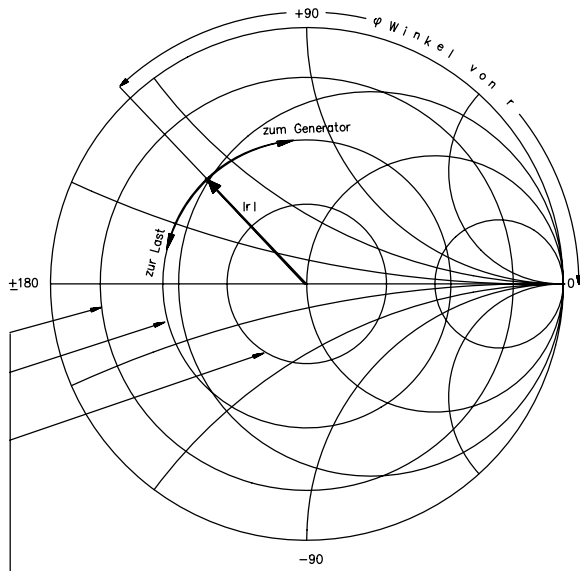

Kreise konstanter Reflexionsfaktore
($|r| = \text{konstant}$)

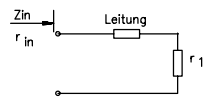

B	S	Suszeptanz
C	F	Kapazität
C'	F/m	Kapazitätsbelag
c_o	m/s	Ausbreitungsgeschw. im fr. Raum = $2.997925 \cdot 10^8$ m/s
E	V/m	Elektrische Feldstärke (Vektor)
f	Hz	Frequenz
G	S	Konduktanz, Leitwert
G'	S/m	Ableitungsbelag
I	A	Strom
I_h	A	Strom der hinlaufenden Welle
I_r	A	Strom der rücklaufenden (reflektierten) Welle
L	H	Induktivität
L'	H/m	Induktivitätsbelag
l	m	Leitungslänge
l_{el}	m	elektrische Länge der Leitung
l_{mech}	m	mechanische Länge der Leitung
m		Anpassungsfaktor
P	W	Leistung
p_v	W/m	Verlustleistung pro Längeneinheit
R	Ω	Widerstand
R'	Ω/m	Widerstandsbelag
RL	dB	Rückflusdämpfung, Returnloss
r		Reflexionsfaktor
r_1		Reflexionsfaktor am Eingang der Leitung
r_2		Reflexionsfaktor am Ausgang der Leitung
s		Welligkeitsfaktor, Stehwellenverhältnis
t	s	Zeit
t_e	m	Eindringtiefe des Stromes
U	V	Spannung
U_h	V	Spannung der hinlaufenden Welle
U_r	V	Spannung der rücklaufenden (reflektierten) Welle

v_d	m/s	Ausbreitungsgeschwindigkeit in Leitung mit Dielektrikum
v_r		relative Ausbreitungsgeschwindigkeit
Y	S	Admittanz $Y=G+jB$
Z	Ω	Impedanz $Z=R+jX$
Z_1	Ω	Eingangsimpedanz
Z_2	Ω	Ausgangs- oder Abschlussimpedanz
Z_F	Ω	Feldwellenwiderstand
Z_{F0}	Ω	Feldwellenwiderstand im Vakuum
Z_0	Ω	Wellenwiderstand der Leitung
α	Np/m	Dämpfungsbelag (1 Np=8.686 dB)
α_G	Np/m	Ableitungsdämpfung
α_R	Np/m	Widerstandsdämpfung
β	Rad/m	Phasenbelag
γ		Ausbreitungsmass $=\alpha+j\beta$
δ_G	Rad	Verlustwinkel des Dielektrikums
ϵ_0	F/m	Dielektrizitätskonstante im fr. Raum $=8.854 \cdot 10^{-12}$ F/m
ϵ_r		relative Dielektrizitätskonstante
λ	m	Wellenlänge
μ_0	H/m	Permeabilitätskonst. im fr. Raum $=4\pi \cdot 10^{-7}$ H/m
μ_r		relative Permeabilitätskonstante
ρ	$\Omega \cdot \text{mm}^2/\text{m}$	spezifischer Widerstand
φ	Rad	Winkel
ω	Rad/s	Kreisfrequenz